

HEADBOARD AND FOOTBOARD SET ASSEMBLY INSTRUCTION (TOTAL 1 BOX)

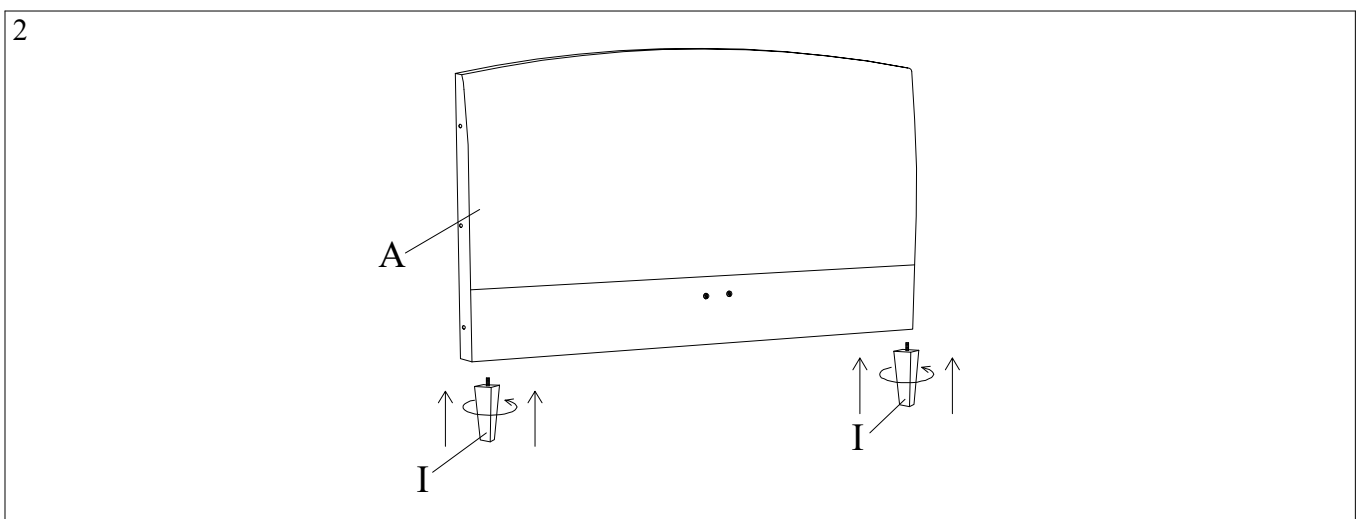

3

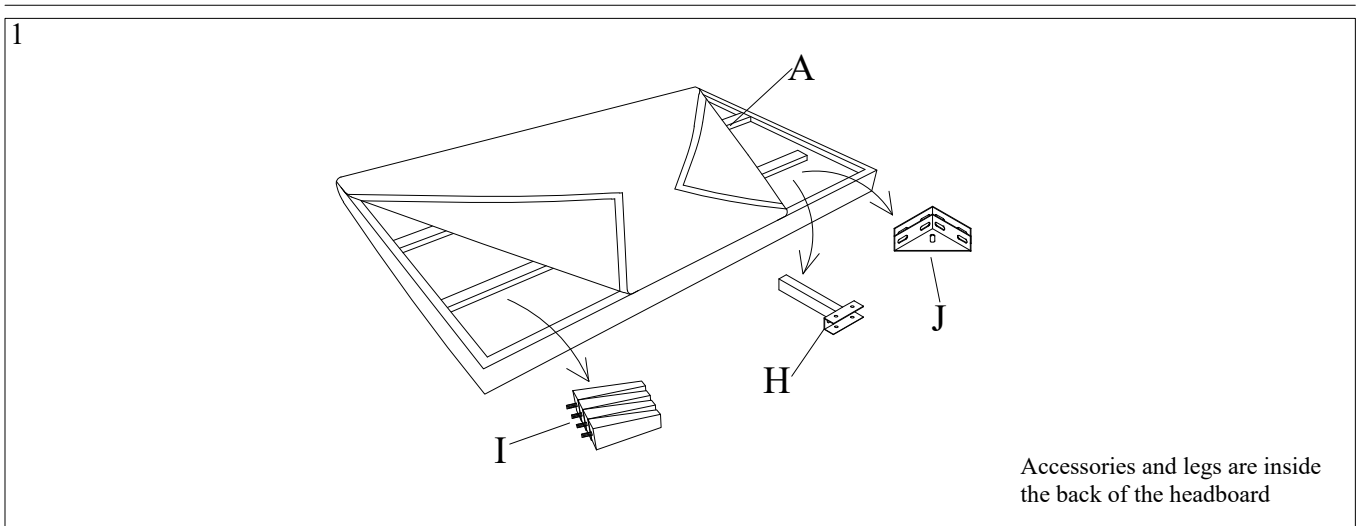
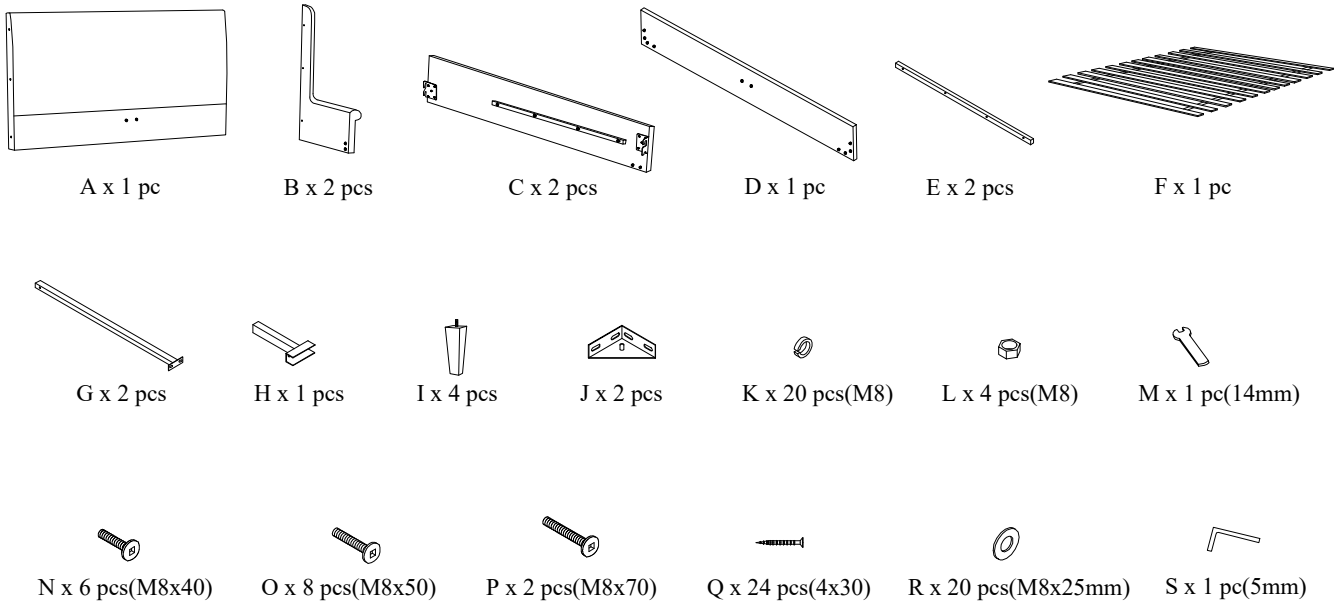
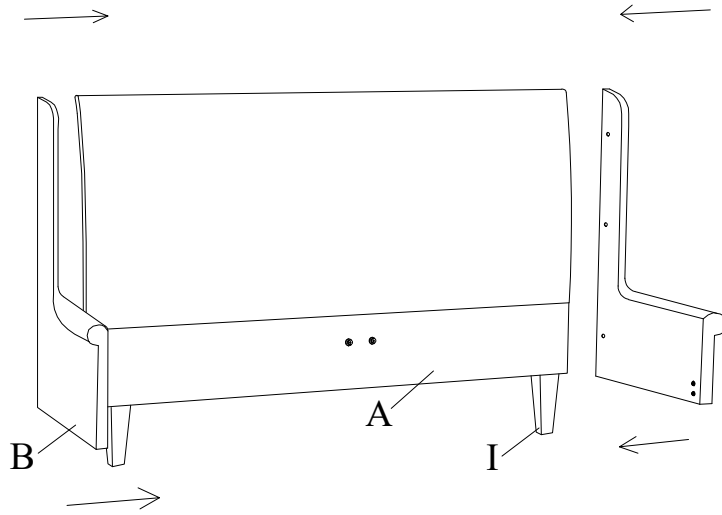

4

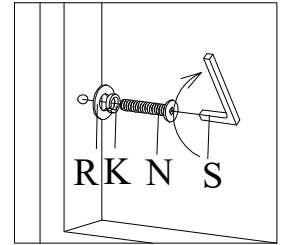
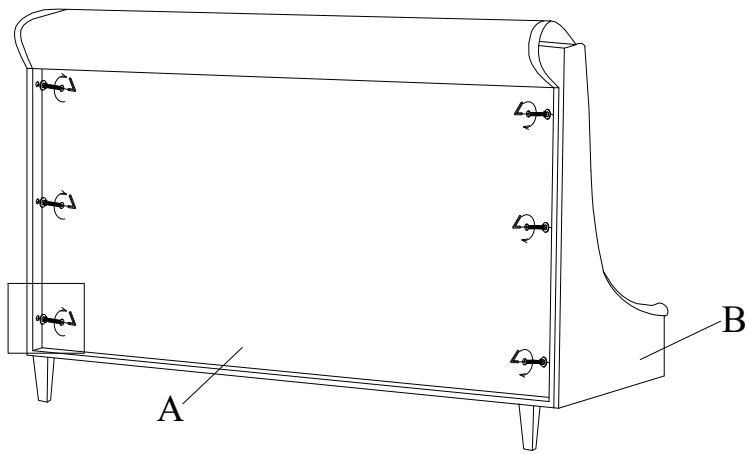

5

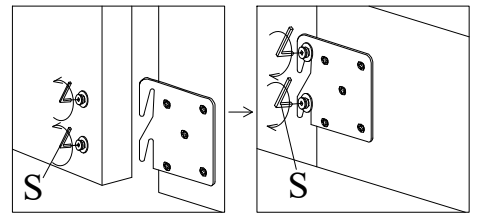
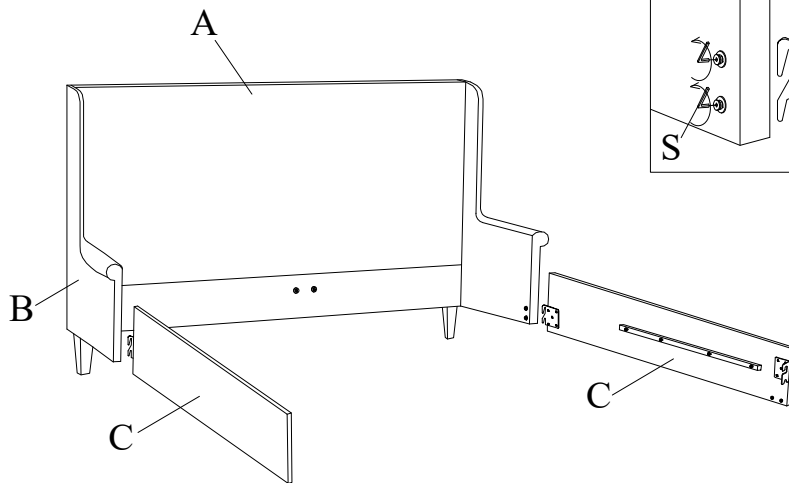

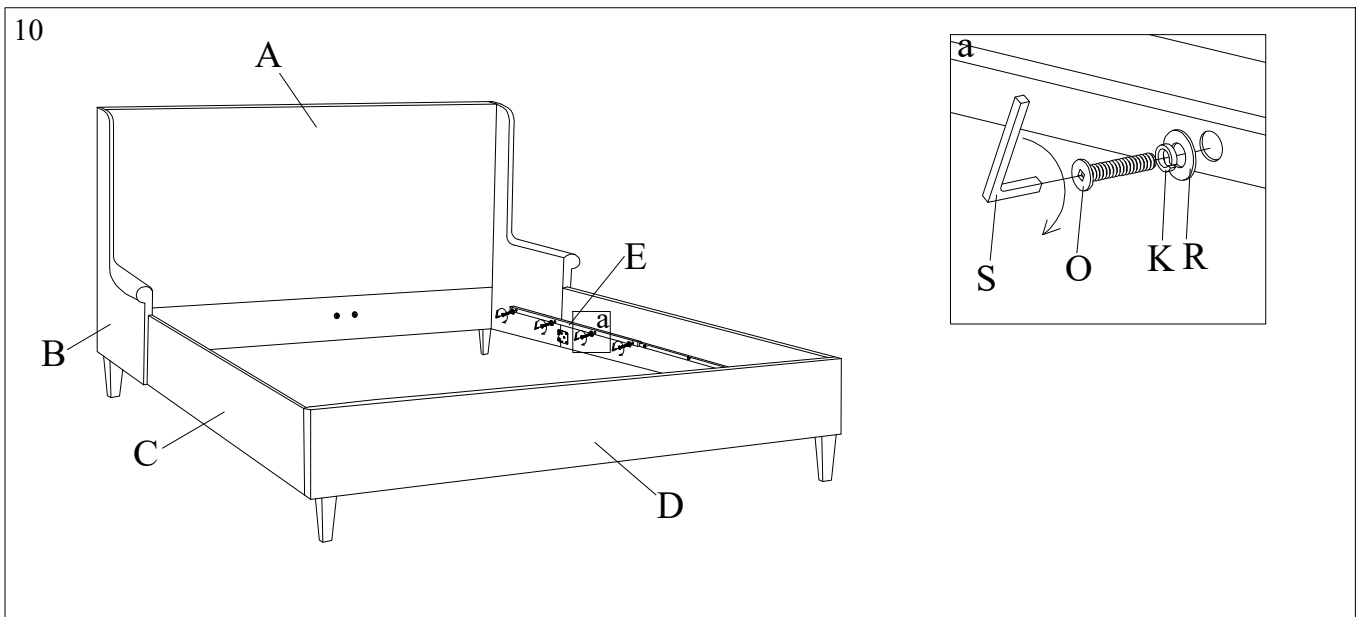
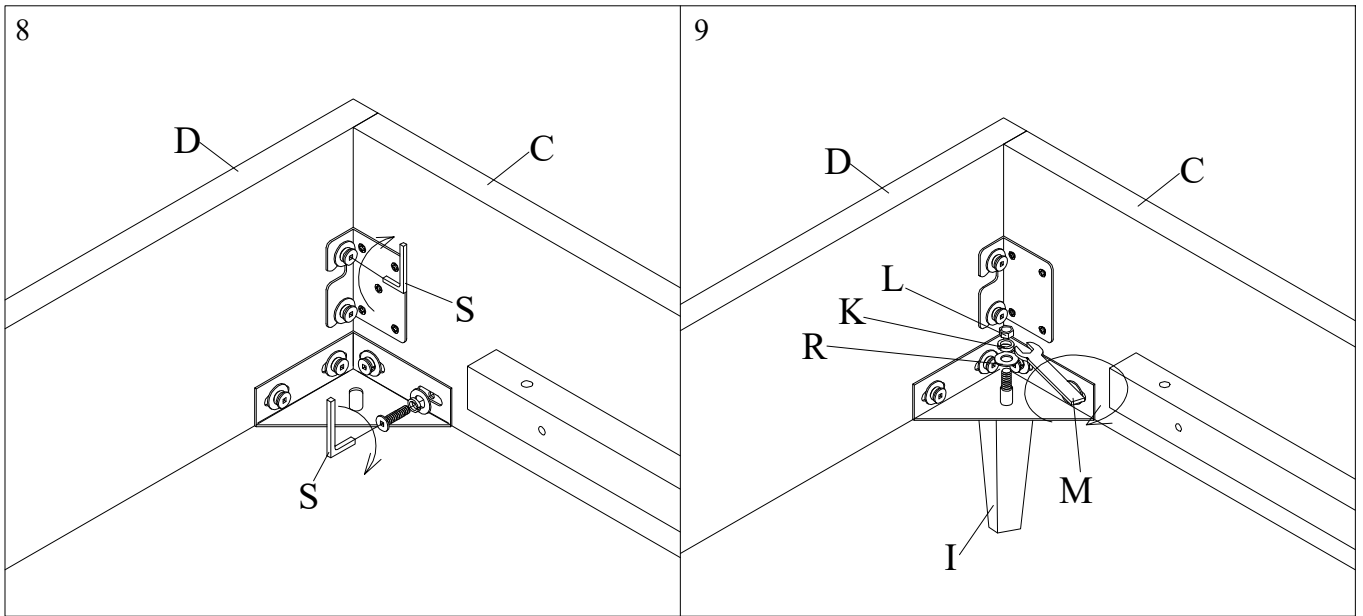
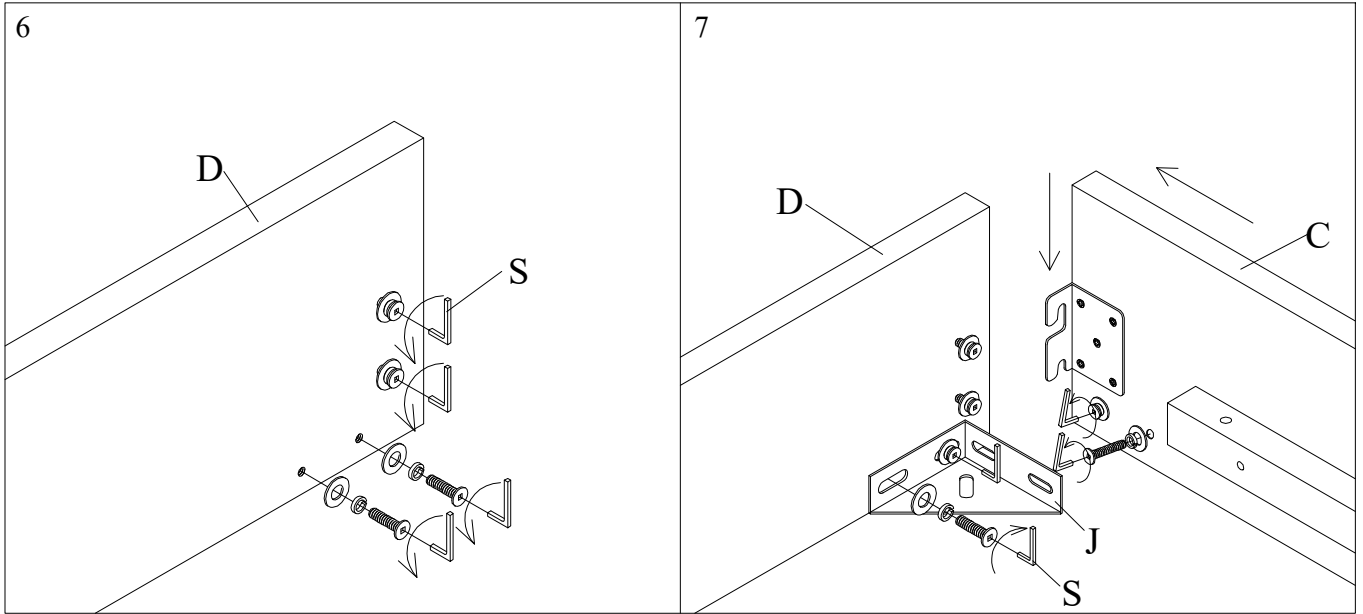

11

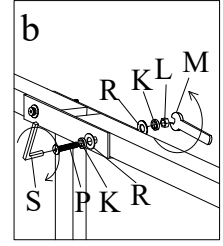
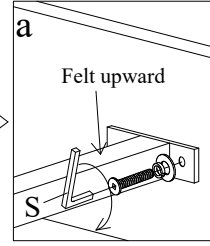
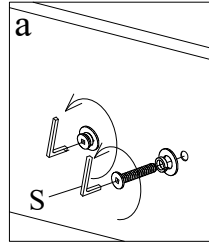
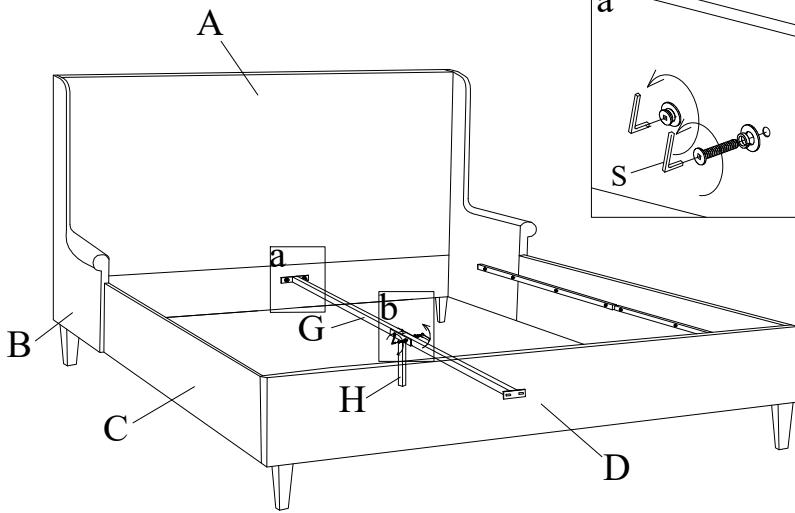

12

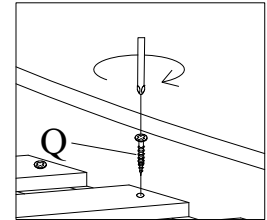
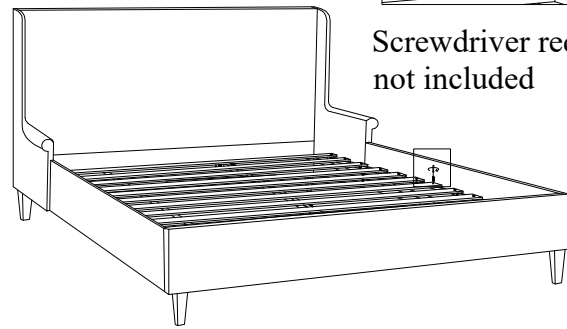
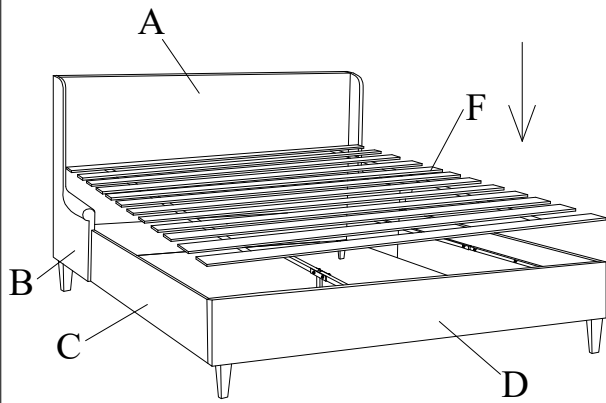

Screwdriver required, not included

13

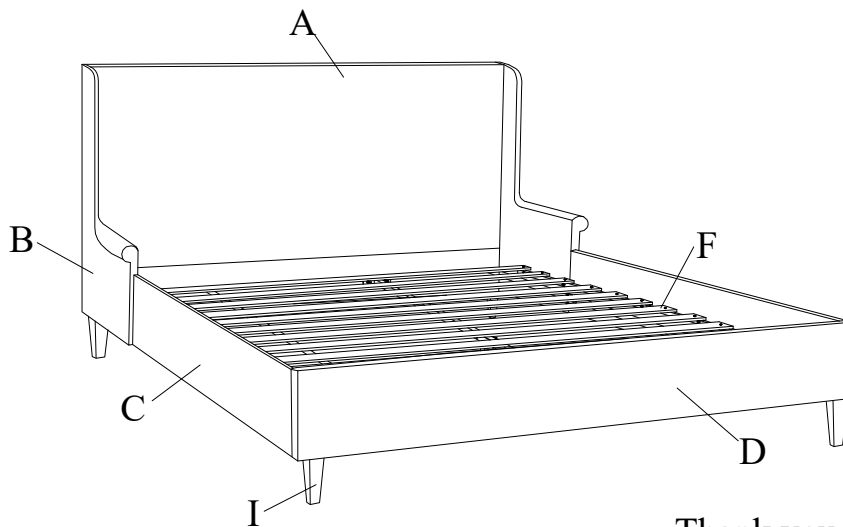

Thank you for your purchase.